

# CONTROL REQUIREMENTS FOR OPTIMAL OPERATION OF LARGE ISOLATED SYSTEMS WITH INCREASED WIND POWER PENETRATION

*N.Hatziargyriou, M.Papadopoulos, S. Tentzerakis*  
*NTUA, Greece*

*J.A. Pecas Lopes, M.H.Vasconcelos, C.D.M.Monteiro*  
*INESC, Portugal*

*G.Kariniotakis, E.Nogaret*  
*ARMINES, France*

*N. Jenkins, M.L.V.Lisboa*  
*UMIST, UK*

## ABSTRACT

Increased penetration of wind power in isolated systems may cause steady state and dynamic security problems in case of various disturbances. In this paper, initial results of studies of large systems with high wind penetration are presented, revealing their control requirements in order to increase renewables, while maintaining a high level of security of operation.

## 1. INTRODUCTION

The European project JOU2-CT92-0053, [1], has proven the feasibility and usefulness of incorporating in a secure way a larger share of renewable energy in isolated systems. Based on this experience, an adaptable advanced control software that aims to achieve optimal utilization of multi-renewable energy sources, in a wide variety of medium and large size isolated systems with diverse structures and operating conditions is being developed. The insurance of increased security and reliability of the system will allow maximization of renewables penetration.

In order to investigate the effects of increased wind penetration in large isolated systems 4 islands have been identified as being the most suitable to provide the requirements for the advanced control software proposed.

- Crete (300 MW)
- Terceira (16 MW)
- Shetland Islands (30 MW)
- New Caledonia (250 MW)

These systems have been selected based on the widely different characteristics they present. Thus, they are composed of different types of networks, they follow different operating philosophies and they comprise various types of renewables. In this paper, initial results of studies of these systems are presented, revealing their control requirements in order to increase renewables penetration, while maintaining a high level of security of operation.

## 2. CRETE

### 2.1 The power system

The power system of the island of Crete is the largest autonomous power system in Greece. It comprises two power stations, one in Linoperamata and the other one in Hania, equipped with diesel engines, gas and steam turbines. According to the planning of the Public Power Corporation of Greece (PPC), the one line diagram of the High Voltage (HV) power system of Crete in the year 2000 is shown in figure 1. In this network all the HV transmission lines operate at 150 kV. The maximum power demand in the year 1997 is approximately equal to 300

MW. The corresponding load demands in 2000 have been estimated to be equal to 360 MW. The wind power that is expected to be installed by the year 2000 will be produced by 10 wind parks. These parks will be installed in sites indicated in figure 1. The wind power will be approximately equal to 80 MW which means that the wind penetration in the year 2000 will exceed the 20% in peak load condition. All the wind turbines will be connected to the grid, which will be properly extended, through 0.7/20 kV step-up transformers. All the generators of the wind turbines will be asynchronous except the ones installed in Ahladia site. Each wind turbine equipped with induction generator will comprise power factor correction capacitors.

It should be noted that the largest part of the wind power is to be installed in the eastern part of the island, nearby Sitia, where the wind conditions are most favorable. This means that, if a fault occurs near this site causing the tripping of the nearby circuit breakers, a large amount of power will be lost suddenly. This abnormal condition may impose serious disturbances on the system.

### 2.2 Examined scenarios

The scenarios used for the simulation of the dynamic behavior of the system include some of the most extreme disturbances. For example, if a large number of wind turbines is disconnected from the grid due to a short circuit it is important to examine the reaction of the conventional units. It is also important to simulate the behavior of the system if the disturbance occurs near the power stations. The following cases have been studied:

- Three phase and one phase to ground short circuit at Sitia
- Three phase short circuit at Rethimno and Kastelli
- Two phase short circuit at Rethimno
- Disconnection of a conventional unit and a wind park

### 2.3 Summary of results

Frequency variations that appear after extreme disturbances can be occasionally very significant. If a fault happens near the substation of Sitia, the corresponding breakers will cause the disconnection of the wind parks from the main grid. This leads to a frequency drop that

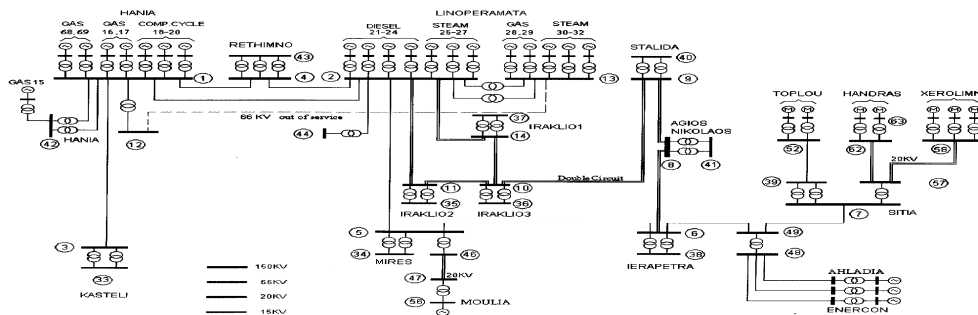

Fig 1. Generation and Transmission system of Crete in year 2000

may reach the 0.5 Hz, that is considered as the acceptable limit. More serious frequency variations appear if a three phase short circuit occurs near a power station. In that case, variations may exceed 0.5 Hz and reach 1 Hz. However, the frequency response of the system is much related to the spinning reserve of the conventional units. Voltage variations that appear even after extreme disturbances are not significant. Extreme abnormal conditions may appear in case of isolated operation of the wind turbines installed in Sitia. In this case self-excitation phenomena of the induction generators may happen, leading to the appearance of severe overvoltages.

As a conclusion, it should be noted that it is possible to operate the power system of Crete with a high level of wind penetration maintaining a high level of security. This is possible, provided adequate spinning reserve of the conventional units is available.

### 3. TERCEIRA

#### 3.1. The power system

Although presently in the island of Terceira in Azores, Portugal, there are no wind parks in operation, a considerable amount of wind power production is foreseen for a near future. Two wind parks, located in two opposite regions of the island, are foreseen:

- Serra do Cume with an installed capacity of about 3 MW (utility owned);
- Santa Bárbara with about 1.8 MW of installed capacity (private owned).

Wind asynchronous generators of 300 kW were considered as the machines to be used. The reactive consumption of these generators was partially compensated through local capacitors connected in parallel. According to the investment plan of EDA (Electricity of Azores) a SCADA system will be installed soon to help in monitoring and controlling the network.

Figure 2 describes the main topological configuration of the network for the year 1999. Presently there are two Diesel power stations and three mini-hydro plants. However, the Diesel power station of Angra do Heroísmo is being decommissioned because of its situation inside the city limits. The Diesel power plant of Belo Jardim, is replacing the old plant of Angra do Heroísmo. The hydro power production of the network was represented by the 0,9MVA

unit, situated at the power station of Nasce Agua. The hydro units of the system do not participate in the speed regulation, and therefore this task is assigned to Diesel machines.

The impact studies related with the presence of 4.8 MW of wind generation were conducted by comparing the system behaviour with and without wind power for the same levels of load consumption. These studies included a steady-state analysis in order to evaluate impacts in the values of the network losses and voltage profiles. Also a dynamic behaviour analysis was performed to evaluate the impact in the system, resulting from the presence of the wind parks, following several disturbances.

#### 3.2 Examined scenarios

The following set of disturbances were simulated in various scenarios of peak and off-peak loads, with and without wind power production.

**Disturbance 1:** Three-phase short-circuit in Angra do Heroísmo (bus 7), eliminated after 200 ms, with and without disconnecting Santa Barbara wind park.

**Disturbance 2:** Disconnection of wind park / Connection of load, i.e. sudden disconnection (at 1 s) of the wind park of Santa Bárbara (6 x 300 kW = 1.8 MW), for the scenarios where wind power is present in the network and sudden increase in the load consumption in the amount of 1.8 MW, at 1s, at the 15 kV bus of Belo Jardim power station, for the scenarios where no wind power was being produced.

**Disturbance 3:** Variation in wind power production. Simulated by changing the mechanical power output of the equivalent wind turbines.

#### 3. Conclusions

From the preliminary studies performed so far in the Terceira electrical network we can conclude that, in general, the introduction of a large share of wind power in this system will be beneficial for its steady state operation and dynamic behavior.

- Generally speaking, the system has shown to be robust, even allowing a large penetration from wind power during off-peak hours.

- In most of the cases, the presence of wind power contributed for better damping characteristics of the system.

- The system presented a quite reasonable dynamic behaviour regarding wind power disturbances even in the most severe conditions.

- During off-peak hours with maximum wind power

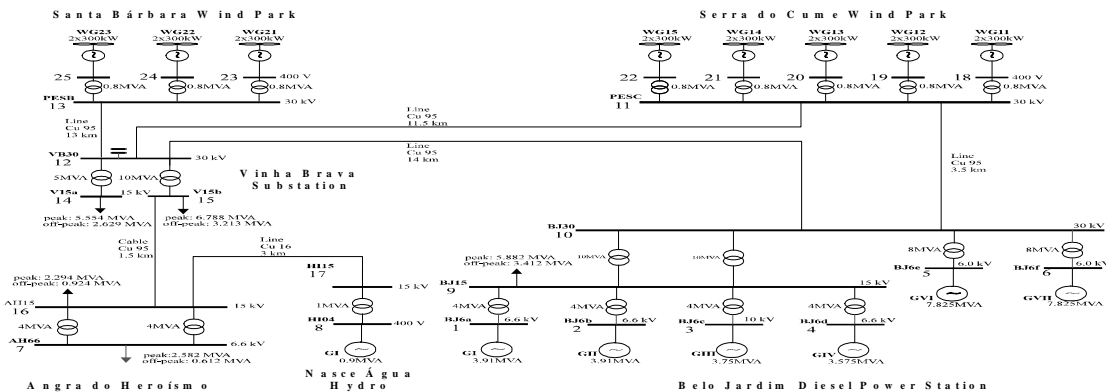

Fig 2. Single line diagram of the Terceira electrical network

penetration the degree of dynamic security of the system is however reduced, especially if short-circuits take place in the system provoking the disconnection of a large amount of wind generators. In this case, although the system shown to be dynamically stable, large frequency excursions appeared. That may lead to the operation of protection devices that afterwards would provoke the system collapse.

- Clearly, during off-peak hours, the dynamic behaviour depends on the number and type of Diesel units (small or large machines) in operation.

From these studies we think that an advanced control system will be quite helpful to manage system operation, specially during off-peak hours with very large wind power penetration, by suggesting: a) the most adequate Diesel machines to be in operation or b) the disconnection of some wind generators.

### 3. NEW-CALEDONIA

The French island of New Caledonia is located 1500 km east of Australia in the Pacific Ocean. The annual energy demand is 1.400 GWh (1994, +9%). The power demand is between 150-250 MW from which 85 % is reserved for the nickel mining and melting industry of the island (New Caledonia has more than 25 % of the world's known nickel resources). The total installed power is 280 MW. In the following Table, the types of power plants are given. In 1995 a wind park, that contains 12 units of 225 kW each, has been installed at the site of Mont Dore. The annual production of the park is estimated at 7 GWh. The installed wind power will be increased to 7.2 MW until year 2000. The structure of the power grid is shown in Figure 3. Apart from the main grid, in New Caledonia there are also 10 hydroelectric micro-stations which are either autonomous or coupled with a diesel station. In addition, 1000 of PV kits are installed for remote houses.

Type of Plant	Installed Units (MW)	Total capacity (MW)
Hydroelectric	4x17, 2x3.6, 1x2.2	77.4
Gas turbine	1x25	25
Steam Plants	4x37	148
Diesel Plants	2x12.4	24.8
Wind Farm	12x0.225	2.7
<b>Total (MW)</b>		<b>280.05</b>

The dynamic behaviour of the power system has been studied in detail. Emphasis was given to the detailed modelling of the hydroelectric plants of the island which have complex structures. The installations consist of systems with multiple hydro-turbines supplied by common tunnels. This configuration results in mechanical oscillations between the turbines during transients. In addition, the existence of surge tanks for the damping of the water hammer effect results in slow dynamics which can be active for several minutes and this contributes negatively to the stability of the power system if additional disturbances happen during this period. A source of such disturbances can be the variable wind production. For this reason a detailed study of wind variations is necessary.

Several simulations were performed to study the impact of the wind park on the dynamic behaviour of the power system. Perturbations due to the operation of the wind generators do not affect significantly the operation of the power system. This is mainly due to the small penetration level achieved by the actual wind park. According to the simulations, the maximal frequency deviation of the system was -0.18 Hz.

In order to examine the impact of higher wind penetration (up to 25%) on the power system dynamic behaviour, four additional wind farms were considered raising the total installed wind power at 40 MW. The pessimistic case of limited geographical dispersion of the wind parks was considered. However, such a scenario is realistic since favourable wind conditions exist only on the southern part of the island. Simulations have shown that the deviations of the power system voltage and frequency remain acceptable under most perturbations examined. However, the situation depends on the scheduling of the power units and the amount of allocated spinning reserve.

The management of a power system like the one of New Caledonia is of special interest due to the multiple types of production units, to the existence of important amount of renewable sources (hydraulic, wind : ~30 % of installed power) and also to the existence of high industrial loads. The operational planning of hydro-units necessitates not only predictions of the water inflow but also predictions of the irrigation needs (if water is used for this purpose- e.g. in the island of Tahiti) in a daily basis. On the other hand, if water storage exists it is feasible to operate thermal units more efficiently. To achieve an economic operation of the power system it is necessary thus to take into account the above constraints as well as the stochastic nature of wind production.

The study of the management strategies applied in power systems that include hydro and wind power plants, as is the case of New Caledonia, but also the analysis of stability and security issues of these systems, is an important input for the design of a control software in order to be as general as possible and applicable to various isolated power systems.

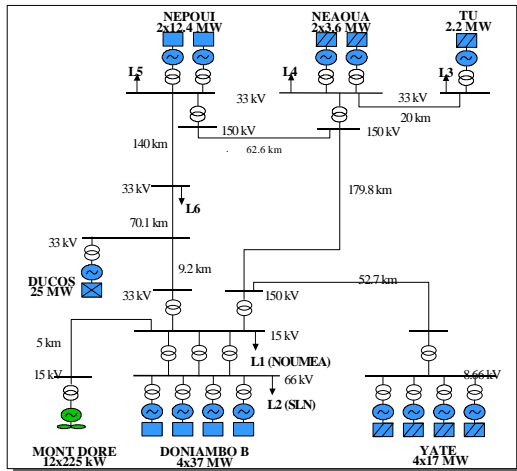

Fig. 3 : Diagram of the power system of New Caledonia.

#### 4. SHETLAND ISLANDS

A simplified network of the Shetland Island 33 kV network is shown in Figure 4. It is a mainly radial distribution system which is supplied by the island power station and by generation of a large oil facility. This system has the following major restrictions to the connection of wind generation:

- There are severe voltage limitations on parts of the network where customer loads are directly connected through 33 / 0.4 kV transformers.
- There is a minimum generation requirement at the island power station.
- At times the oil facility generation supplies part of the network load.

Simulation studies were carried out with several power system analysis programs to determine the location and maximum capacity of wind generation which may be connected to this system. In general, for steady state operating conditions, the maximum wind farm capacity may be limited by the minimum customer load, minimum generation and network voltage restrictions. This capacity can be further reduced if, under transient conditions, the combined power system and wind farm produce unacceptable system disturbances.

A number of possible locations for the wind farm were considered but steady state simulation results indicated that losses are minimised if the wind farm is located as shown in Figure 4. The maximum wind farm capacity was limited by the combination of the minimum generation requirement of the island power station, minimum export from the oil facility and minimum customer load rather than by network voltage restrictions. Several types of disturbances were simulated and the results indicated that the wind farm does not affect adversely the transient behaviour of the Shetland electrical system. In all cases analysed, the combined distribution system and wind farm recovered from the faults which were applied.

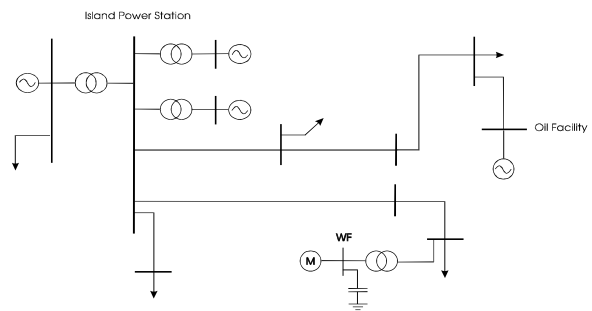

Fig.4 The Shetland Islands reduced network

#### 5. CONCLUSIONS

In all islands studied, it is shown that it is possible to operate their power systems with a high level of wind penetration, provided adequate spinning reserve of the conventional units is available. The optimal determination of this spinning reserve requires the operation of an advanced Control Center that will allow an increase of wind penetration without risking the security of the system by suggesting: a) the most adequate conventional machines to be in operation or b) the disconnection of some wind generators.

#### 6. ACKNOWLEDGEMENTS

The authors would like to acknowledge the financial support of the European Commission in the frame of project JOR3-CT96-0119 under the Non Nuclear Energy Programme. They would also like to thank all the participants of the project, i.e. NTUA, INESC, ARMINES, RAL, UMIST, AUTH, TUC, EFACEC and in particular PPC, EDA and Scottish-Hydro for their assistance.

#### 7. REFERENCES

- Project Joule: JOU-CT92-0053: "Development and Implementation of an Advanced Control System for the Optimal Operation and Management of Medium Size Power Systems with a Large Penetration of Renewable Power Sources", Final Report, EUR 16686, ISBN 92-827-5007-8, June 1995.
- Project Joule: JOR3-CT96-0119: "Advanced Control Advice for Power Systems with large-scale Integration of Renewable Energy Sources", Care 2<sup>nd</sup> Official Report, July 1997.